



FlowTek®

A Subsidiary of BRAY INTERNATIONAL, Inc.

3 Piece Ball Valves Full Port: 1/4" - 4"



Flow-Tek's Series 5000/6000 ball valves offer the convenience of a three piece body design at an economical price. The 3 Piece design with a swing out center section allows for ease of in-line and out-of-line maintenance. Standard valve bodies are investment cast CF8M Stainless Steel or WCB Carbon Steel. All body castings are marked with a foundry heat number for full traceability.

These valves offer quarter turn operation and low operating torque. Series 5000/

6000 valves feature adjustable stem packing, stainless steel safety trigger locking handles and travel stops which limit handle movement to set 90° intervals. Flow-Tek's heavy duty, high quality stems are internal entry and blowout proof for maximum safety.

Each Series 5000/6000 valve features an integrally cast mounting pad complying with ISO 5211 that provides positive alignment when mounting actuators, gear operators or control accessories.

Pressure Rating:

1/4"-2": 1000 psi WOG
2-1/2"-4": 800 psi WOG

Temperature Range:

-50°F to +450°F
-46°C to +232°C

End Connections:

Threaded (NPT): SS CF8M or CS WCB
Socket Weld: SS CF3M or CS WCB

Body Material:

5000: Stainless Steel CF8M
6000: Carbon Steel WCB



Jamieson Equipment Company
www.jamiesonequipment.com
toll free 800.875.0280

COMPONENTS AND MATERIALS

Item	Name	Material	Qty.
1	Body •	ASTM A351 Gr CF8M	1
2	End Cap •	ASTM A351 Gr CF8M	2
3	Ball	ASTM A479 Type 316	1
4	Seat ••	RPTFE	2
5	Stem	ASTM A479 Type 316	1
6	Body Seal ••	PTFE	2
7	Washer	SS304	*
8	Body Nut	SS304	*
9	Body Bolt / Stud	SS304	**
12	Thrust Washer ••	PTFE	1
14	Stem Packing ••	PTFE	1
15	Gland Nut	SS304	1
19	Handle Washer	SS304	1
23	Stop Set Sleeve	SS304	1
24	Stop Bolt	SS304	1
25	Handle	SS304***	1
26	Handle Nut	SS304	2
28	Handle Sleeve	Vinyl	1
29	Locking Device	SS304	1

BODY AND END CAP MATERIALS

- 5000 Body: CF8M
Threaded End: CF8M
Weld End: CF3M
- 6000 Body & Ends: A216-WCB

SPECIFICATIONS

All Series 5000/6000 valves comply with, and are tested in accordance with, MSS-SP 72. Vacuum Service to 29 inches Hg. gauge. Threaded End Connections meet ASME B1.20.1 NPT. Socket Weld End Connections meet ASME B16.11.

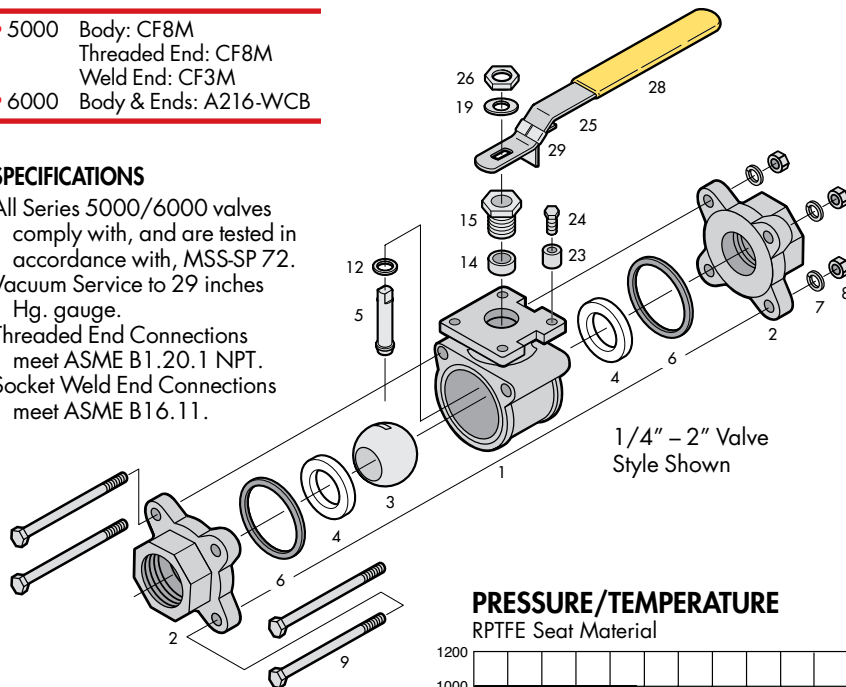

* Number of Nuts & Lock Washers: 1/4"-2" Valves4
2-1/2"-3" Valves8
4" Valves12

** Number of Body Bolts or Studs: 1/4"-2"4 (Bolts)
2-1/2"-3"4 (Studs)
4" Valves6 (Studs)

*** Handles on 3" - 4" are Carbon Steel

•• Parts included in the repair kits

Note: Carbon Steel valves limited to -20°F.

PRESSURE/TEMPERATURE

RPTFE Seat Material

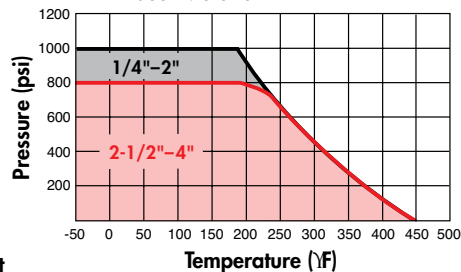

DIMENSIONS AND WEIGHTS

*Torque based on RPTFE seats in clean water at full rated pressure. Torque Weight

Size ins mm	A	øB Port	C	C1	D	øE	F	ød	M	øP	U	Cv	lbs-in* Nm	lbs kg
1/4 8	2.4 60	0.46 11.6	2.6 67	1.5 37.7	4.7 120	0.57 14.4	0.5 12	FO3 1.42 36	0.20 5	0.31 7.9	M5	8	60 7	1.0 0.45
3/8 10	2.4 60	0.49 12.5	2.6 67	1.5 37.7	4.7 120	0.70 17.8	0.5 12	FO3 1.42 36	0.20 5	0.31 7.9	M5	8	60 7	1.0 0.43
1/2 15	3.0 75	0.59 15	2.9 73	1.8 44.7	4.7 120	0.87 22	0.5 12	FO3 1.42 36	0.20 5	0.37 9.4	M5	32	70 8	1.4 0.6
3/4 20	3.0 77	0.79 20	3.0 76	1.9 48	5.7 145	1.10 27.4	0.6 14	FO3 1.42 36	0.26 6.5	0.37 9.4	M5	54	95 11	1.75 0.74
1 25	3.4 85	0.98 25	3.3 84	2.3 58.5	6.1 155	1.34 34.1	0.6 15	FO4 1.65 42	0.31 8	0.45 11.4	M5	105	140 16	2.45 1.04
1 1/4 32	4.1 104	1.26 32	3.5 89	2.5 63.1	6.1 155	1.69 42.9	0.7 17	FO4 1.65 42	0.31 8	0.45 11.4	M5	200	195 22	4.0 1.72
1 1/2 40	4.7 120	1.50 38	4.1 103	3.0 76.6	6.7 170	1.93 49	0.7 17	FO5 1.97 50	0.33 8.5	0.63 16	M6	275	315 36	5.6 2.46
2 50	5.1 130	1.97 50	4.3 109	3.3 83.5	6.7 170	2.42 61.5	0.8 20	FO5 1.97 50	0.33 8.5	0.63 16	M6	500	510 58	8.7 3.8
2 1/2 65	6.5 165	2.56 65	5.2 132	4.5 114.2	9.1 230	3.03 77	0.9 23.8	FO7 2.76 70	0.47 12	0.79 20	M8	780	730 82	17.7 8.2
3 80	7.2 182	2.99 76	5.5 140	4.8 122	9.1 230	3.54 90	1.0 25	FO7 2.76 70	0.47 12	0.79 20	M8	1150	990 112	25.0 11
4 100	9.1 230	3.82 97	6.9 176	6.5 164.3	10.8 275	4.54 115.4	1.2 30	F10 4.02 102	0.63 16	0.98 25	M10	1700	3100 350	52.0 23.5

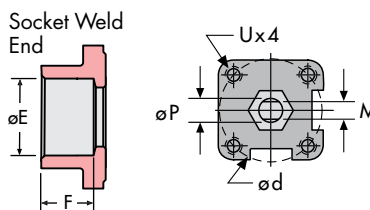
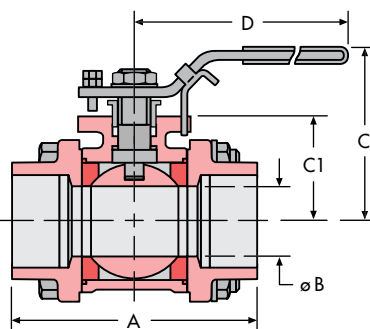

Verify mounting dimensions before manufacturing mounting hardware.

Automated valves may require periodic gland nut adjustments.